



## Features:

- Energy (Active)
- Programmable CT Primary/Secondary
- Pulse Output

Size: 1/4 DIN 96mm x 96mm

Certifications: CE  PENDING

## Technical Specifications

### Display

Display	7 segment LED display
Digit	6
Digit Height	0.56" (14.2mm)
Display Range	999999

### Input Specifications

Electrical Connection	3Ø-3/4 wire, 2Ø-3 wire, 1Ø-2 wire
Rated Input Voltage	19 to 519V AC, (Phase to Phase) 50/60Hz 11 to 300V AC, (Phase to Neutral) 50/60Hz
Rated Input Current	10mA - 5A (6A Max)
LED Indication	INT - Integration of energy X10 - Resolution is 10 REV - Reverse connected CT warning
Burden	0.5 VA@5A per phase
Frequency	45 to 65Hz
Resolution	0.01, 0.1, 1 & 10 (depending on CT ratio)

### Output Specifications

Output	Pulse Output: Voltage range - 24 VDC Current capacity-100 mA max Pulse Width: 100 ms ± 50 ms.
--------	---

### Supply Specifications

Auxiliary Supply	85 to 270V AC, 50/60Hz
------------------	------------------------

### Resettable Parameters

C.T Primary	1A/5A to 10,000A programmable for any value
C.T Secondary	1A/5A (External CT must be connected for current more than 5A)

### Environmental Specifications

Temperature	Operating: 0 to 50 °C Storage: -20 to 75 °C
Humidity (non-condensing)	Upto 85% RH

### Mechanical Specifications

Mounting	Panel mount
Weight	225 gms
Protection Level	IP65 for faceplate

### Dimensions

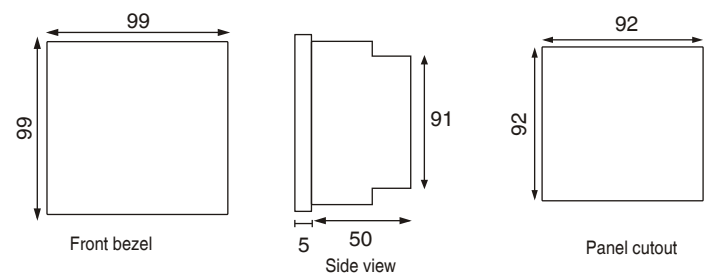

### Terminal Connections

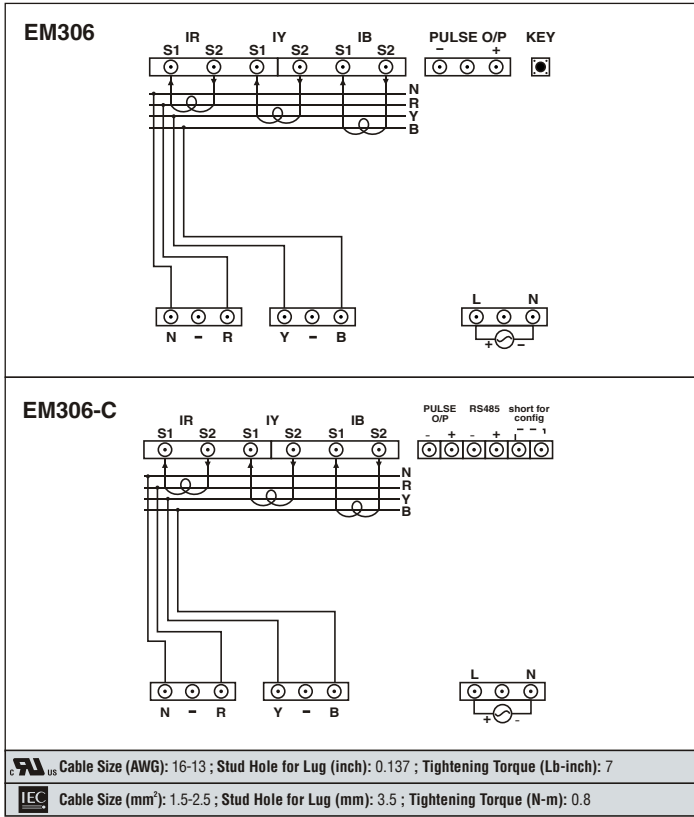

### Ordering Information

Part No.	Supply Voltage	Output	
	90-270V AC	Pulse Output	Commn (RS485)
EM306	■	■	
EM306-C	■	■	■

**EN-VIEW:** Windows based communication software available for data logging.

# selec

EM306/EM306-C (96x96)

Operating Instructions



EM306-C(96x96)

EM306(96x96)

## FEATURES

- 6 digit 7 segment LED display.
- User programmable CT primary.
- Memory retention.
- Potential free Pulse output for energy.
- 90 to 270V AC/DC auxiliary supply.
- RS485 communication (MODBUS Protocol) (Applicable for EM306-C Only)

## SPECIFICATIONS

### DISPLAY

6 digit 7 segment LED display. Height 0.5"

### LED INDICATIONS

INT - Integration of energy

X10 - Resolution is 10

REV - Reverse connected CT warning

### INPUT

3 Ø - 4 wire and 1 Ø - 2 wire input type

### RATED INPUT VOLTAGE

Nominal 300V AC max.

3-phases(R,Y,B) with respect to Neutral

### FREQUENCY RANGE

50 Hz

### RATED INPUT CURRENT

Nominal 6A maximum

### CT PRIMARY

5 to 5000

### BURDEN

0.5 VA @ 5A per phase

### MEASUREMENT

kWh (resettable)

### ACCURACY

Class 1

### AUXILIARY SUPPLY RANGE

90 to 270V AC / DC, 50/60 Hz

### OUTPUT

#### Pulse Output:

Voltage range - 24V DC

Current capacity - 100mA max

#### Pulse Width:

500 ms ± 50 ms.

## RESOLUTION

CT Primary	kWh	INT blink (kWh/blink)	Pulse output (kWh/pulse)
≤10	0.01	0.001	0.01
10 > CT primary ≤100	0.1	0.01	0.1
100 > CT primary ≤1000	1	0.1	1
>1000	10	1	10

**NOTE :** Auto shift of resolution after display reaches maximum display point. For example resolution is shifted to 1 after 99999.9 kWh. After 999999 with resolution of 10 display rolls back to 0 and resolution shifts as per CT primary selected.

**TEMPERATURE :** Operating : 0 to 50 °C  
Storage : -20 to 75 °C

**HUMIDITY :** 85% non-condensing

**MOUNTING :** Panel mounting

**WEIGHT :** 225 gms

## SERIAL COMMUNICATION (Applicable for EM306-C Only)

<b>Interface standard &amp; protocol</b>	RS485 & MODBUS RTU
<b>Communication address</b>	1 to 255
<b>Transmission mode</b>	Half duplex
<b>Data types</b>	Float and Integer
<b>Transmission distance</b>	500 m maximum
<b>Transmission speed</b>	300, 600, 1200, 2400, 4800, 9600, 19200 (in bps)
<b>Parity</b>	None, Odd, Even
<b>Stop bits</b>	1 or 2
<b>Response time</b>	100 ms (max and independent of baud rate)

## SAFETY PRECAUTIONS

All safety related codifications; symbols and instructions that appear in this operating manual or on the equipment must be strictly followed to ensure the safety of the operating personnel as well as the instrument.

If the equipment is not handled in a manner specified by the manufacturer it might impair the protection provided by the equipment.

**CAUTION:** Read complete instructions prior to installation and operation of the unit.

**CAUTION:** Risk of electric shock.

## WIRING GUIDELINES

### WARNING:

- To prevent the risk of electric shock power supply to the equipment must be kept OFF while doing the wiring arrangement.
- Wiring shall be done strictly according to the terminal layout. Confirm that all connections are correct.
- Use lugged terminals.
- To eliminate electromagnetic interference use of wires with adequate ratings and twists of the same in equal size shall be made.
- Cable used for connection to power source, must have a cross section of 1.5mm<sup>2</sup>. These wires shall have current carrying capacity of 5A.

## MAINTENANCE

- The equipment should be cleaned regularly to avoid blockage of ventilating parts.
- Clean the equipment with a clean soft cloth. Do not use Isopropyl alcohol or any other cleaning agent.

## INSTALLATION GUIDELINES

### CAUTION:

- This equipment, being built-in-type, normally becomes a part of main control panel and in such case the terminals do not remain accessible to the end user after installation and internal wiring.
- Conductors must not come in contact with the internal circuitry of the equipment or else it may lead to a safety hazard that may in turn endanger life or cause electrical shock to the operator.
- Circuit breaker or mains switch must be installed between power source and supply terminals to facilitate power 'ON' or 'OFF' function. However this switch or breaker must be installed in a convenient position normally accessible to the operator.
- Before disconnecting the secondary of the external current transformer from the equipment, make sure that the current transformer is short circuited to avoid risk of electrical shock and injury.

### CAUTION:

- The equipment shall not be installed in environmental conditions other than those mentioned in this manual.
- The equipment does not have a built-in-type fuse. Installation of external fuse of rating 275VAC/1Amp for electrical circuitry is highly recommended.
- Thermal dissipation of equipment is met through ventilation holes provided on chassis of equipment. Such ventilation holes shall not be obstructed else it can lead to a safety hazard.
- Connectors screws must be tightened after Installation.

## MECHANICAL INSTALLATION

### EM306/EM306-C

For installing the meter

- Prepare the panel cutout with proper dimensions as shown below :

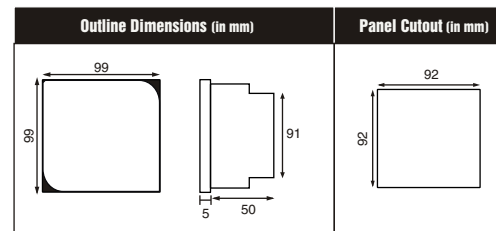

- Push the meter into the panel cutout. Secure the meter in its place by pushing the clamp on the rear side. The screws, of the pane of the clamp, must be in the farthest forward slot.
- For proper sealing, tighten the screws evenly with required torque.

### CAUTION :

The equipment in its installed state must not come in close proximity to any heating sources, caustic vapors, oils, steam, or other unwanted process by-products.

## EMC Guidelines:

- Use proper input power cables with shortest connections and twisted type
- Layout of connecting cables shall be away from any internal EMI source.

## TERMINAL CONNECTIONS

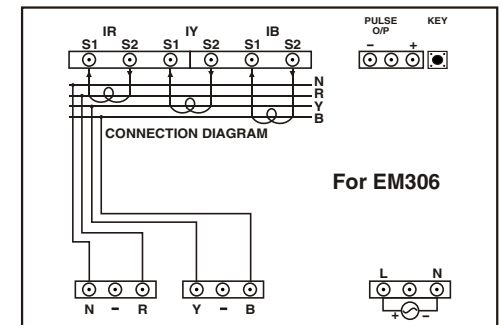
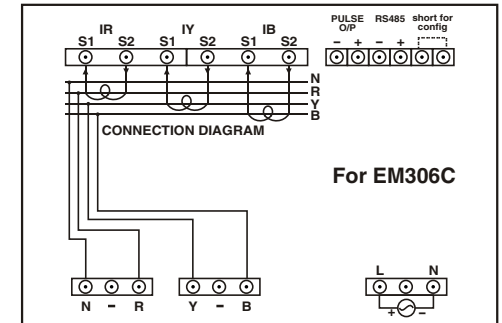

## FRONT PANEL DESCRIPTION

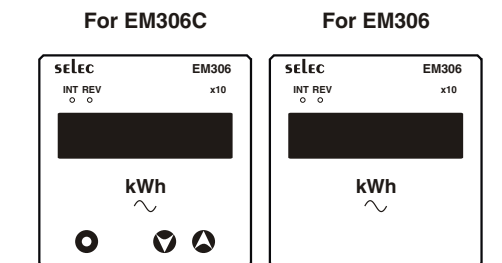

## LED INDICATIONS

- INT : LED blinks when integration of energy is in progress.
- X10 : LED is ON when the resolution is 10
- REV: LED ON when there is improper wiring or negative power consideration in any or all phases.

## PROGRAMMING SCHEME FOR EM306

The unit can be programmed using the 'tact key' near the terminals. The position of the key is as shown in terminal diagram.

To enter into Programming keep the key continuously pressed and power ON.

### To configure CT primary

Keys description	Display shows
Press  and power ON	

Press the to scroll to the next CT value from the range. When key is pressed & released the value is modified. After last value it rolls back to the first value.

Following are the primary ranges:

5, 30, 40, 50, 60, 75, 80, 100, 150, 200, 250, 300, 400, 500, 600, 800, 1000, 1200, 1500, 1600, 2000, 2500, 3000, 4000, 5000.

**NOTE:** Key has no other function during normal working mode.

## CONFIGURATION SCHEME FOR EM306-C

(parameter setting)

To enter configuration : Short terminals marked as **short for config**

Key press	Display	Description
<b>1. To enter configuration menu</b> Factory setting: 25		
Display		Range: 0 to 999
Press  /		key to change values
Press		key to access next parameters
<b>2. CT ratio</b> Factory setting: 5		
Display		Range: 5 to 5000
Press  /		key to change values
Press		key to access next parameters
<b>3. Slave ID</b> Factory setting: 1		
Display		Range: 1 to 255
Press  /		key to change values
Press		key to access next parameters
<b>4. Baud rate</b> Factory setting: 9600		
Display		Range: 300, 600, 1200, 2400, 4800, 9600, 19200 (in bps)
Press  /		key to change values
Press		key to access next parameters
<b>5. Parity</b> Factory setting: NO		
Display		Range: None, even, odd
Press  /		key to change values
Press		key to access next parameters

### 6. Stop bit

Factory setting: 1

Display

Range: 1 or 2

Press / key to change values

Press key to access next parameters

### 7. Password for Energy Reset

Factory setting: 1000

Display

Press / Range: 0 or 9999

Press key to access next parameters

### 8. Energy Reset

Factory setting: NO

Display

Range: No / Yes

Press / key to change values

Press key to access next parameter

**Note:-** Upon enabling the front reset feature, user should be able to reset the energy by pressing key for 3 sec. after coming out of configuration

### Exit configuration mode:

Do not press any key for 30 sec in configuration mode. or Power OFF and power ON unit again after removing "Short for config"

## APPLICATION OF PULSE OUTPUT

### ● PROCESS INTEGRATION

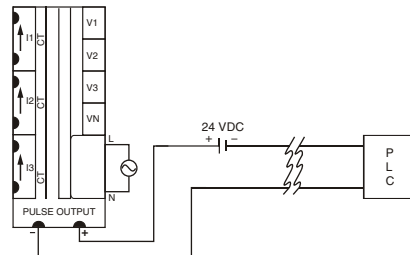

Pulse output from EM306 meter can be interfaced into a process through a PLC for on line control of energy content in the process.

If the PLC has a self excited 24V digital input, external 24V DC supply is not needed.

The kWh pulse is also used to derive average kWh information at the PLC.

## USER GUIDE

What does the INT, REV and X10 LEDs on the front panel indicate ?

● INT: The INT LED provides quick visual indication of energy integration. The blink rate is 10 times per count update and it is depending upon the CT primary. By running at faster rate, the user need not wait long till the counter up dation in the meter.

● X10: X10 LED ON when the resolution is 10. It is the indication of count reading which must be multiplied by 10 to get actual kWh consumed.

● REV: REV LED gives the indication of reversal of two or more CT connections. In such cases meter may not indicate the correct energy consumption. The CT should be connected to the meter with correct polarities.

## NOTE :

- 1) In configuration menu repeated pressing of key will allow toggling between all the configuration parameters
- 2) In configuration menu only after pressing key will the new values of every configurable parameter be updated

## TYPICAL WIRING DIAGRAM

### 3 PHASE 4-WIRE

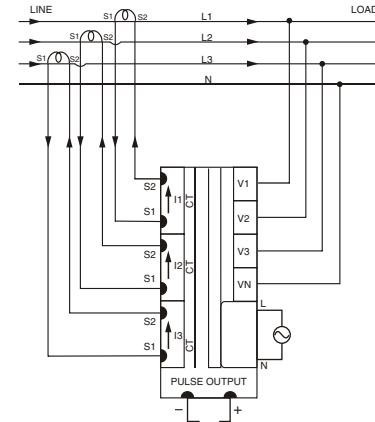

### SINGLE PHASE

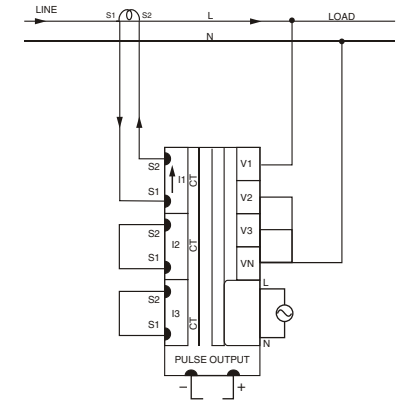

## MODBUS register addresses list (Applicable for EM306-C Only)

Readable parameters from master					
Address	Parameter	Range		Length (Register)	Data Structure
		Min value	Maximum value		
30000	kWh	0	9999999	2	Float

Writable parameters from master					
Address	Parameter	Range		Length (Register)	Data Structure
		Min value	Maximum value		
40000	CT primary	5	5000	1	Integer
40001	Slave ID	1	255	1	Integer
40002	Baud rate	Value	Baud rate	1	Integer
		0X0000	300		
		0X0001	600		
		0X0002	1200		
		0X0003	2400		
		0X0004	4800		
		0X0005	9600		
		0X0006	19200		
40003	Parity	Value	Parity	1	Integer
		0X0000	None		
		0X0001	Even		
		0X0002	Odd		
40004	Stop bit	Value	Stop bit	1	Integer
		0X0000	1		
		0X0001	2		
40005	Front reset	Value	Front reset	1	Integer
		0X0000	Disable		
		0X0001	Enable		
40006	Reset kWh	Value	kWh Reset	1	Integer
		0X0000	No		
		0X0001	Yes		

## Selec Controls Pvt. Ltd.

(Specifications are subject to change, since development is a continuous process)

Telephone: +91-22-40394200 / 40394202

Fax: +91-22-28471733

Toll free: 1800 227 353

Website: [www.selec.com](http://www.selec.com)

Email: [sales@selec.com](mailto:sales@selec.com)